

ELECTROMECHANICAL ANALYSIS LAB  
EMET 3424\_70  
TUESDAY, FEBRUARY 20, 2001  
8:00 - 9:50AM, SET 363

# LAB # 3

---

## LVDT CALIBRATION

**PREPARER:**

Scott Greenberg

Address: 

Phone: 

E-mail: 

**INSTRUCTOR:**

Nicholas Reitter III

Office: SET 3668

Phone: 607-587-4670

E-mail: reitten@alfredstate.edu

**LAB PARTNERS:**

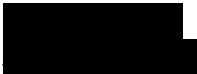

---

**TABLE OF CONTENTS**

---

PREPARER: .....	1
INSTRUCTOR:.....	1
LAB PARTNERS: .....	1
<b>TABLE OF CONTENTS</b> .....	<b>2</b>
<b>LAB OBJECTIVE</b> .....	<b>3</b>
<i>Figure I.1 LVDT</i> .....	3
<b>PART I: CHARACTERISTICS OF AN AC LINEAR VARIABLE DIFFERENTIAL TRANSFORMER (LVDT)</b> .....	<b>5</b>
THEORY .....	5
<i>Figure A1.1 Equation</i> .....	5
<i>Figure A1.2 Equation</i> .....	5
SCHEMATIC.....	6
<i>Figure: A1.3 Mechanical Setup</i> .....	6
<i>Figure: A1.4 Mechanical Setup</i> .....	6
PROCEDURE/DATA COLLECTION.....	6
CALCULATIONS .....	7
RESULTS SUMMARY.....	8
<i>Figure: A1.5 Maximum Deflection</i> .....	8
<i>Figure: A1.6 Minimum Deflection</i> .....	8
<i>Figure: A1.7 Neutral</i> .....	8
<i>Table: A1.1 AC LVDT w/ % ERROR</i> .....	9
<i>Figure: A1.8 AC LVDT</i> .....	9
<i>Figure: A1.9 % Error</i> .....	10
<b>PART II: CHARACTERISTICS OF AN DC LINEAR VARIABLE DIFFERENTIAL TRANSFORMER (LVDT)</b> .....	<b>10</b>
THEORY .....	10
<i>Figure A2.1 Equation</i> .....	10
<i>Figure A2.2 Equation</i> .....	10
SCHEMATIC.....	11
<i>Figure: A2.3 Mechanical Setup</i> .....	11
PROCEDURE/DATA COLLECTION.....	11
CALCULATIONS .....	11
RESULTS SUMMARY.....	12
<i>Table: A2.1 DC LVDT w/ % ERROR</i> .....	12
<i>Figure: A2.4 DC LVDT</i> .....	12
<i>Figure: A2.5 % Error</i> .....	13
<b>DISCUSSION</b> .....	<b>13</b>
<b>WORK CITED</b> .....	<b>14</b>

---

### LAB OBJECTIVE

The objective of this laboratory experiment is to gain experience and practice working with electrical devices. We will use static displacement measurement techniques. A way of measuring linear displacement is by the use of a linear variable differential transformer. The Linear Variable Differential Transformer is a position-sensing device that provides an AC output voltage proportional to the displacement of its core passing through its windings. LVDTs provide linear output for small displacements where the core remains within the primary coils. The exact distance is a function of the geometry of the LVDT.

FIGURE I.1 LVDT

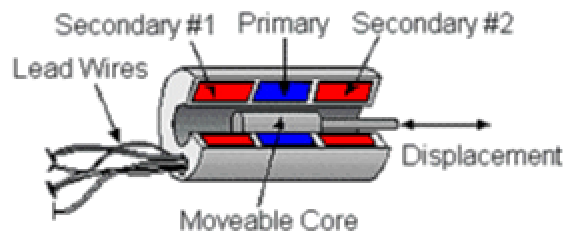

Source: [www.flw.com](http://www.flw.com)

The equipment used in this lab is listed but limited to this list.

- Tektronix TDS 310 Two Channel Oscilloscope, S/N: B040281, Instr. TDS310, Voltage Range: 90 – 132 V, Frequency Range: 47 – 440 Hz
- Daytronic Model 3130 LVDT Conditioner; Miamisburg, Ohio; Serial: 392
- Function Generator on SL10
- Micrometer (in), 0.0001 Division
- Layout Board, PIC Design Corp. Rockaway, NY
- Hewlett Packard 34401A Multimeter, S/N 3146A29090
- Power Supply from SL10
- TQ SL10 Vibrating Beam, Tec Quipment Ltd., Model/Serial: L10/L5619/10
- Micrometer (mm), More & Wright: Sheffield, England
- Semiconductor Strain Gauge on SL10
- SLI System Laboratory S/N: SLI/L5517/9

- Multiple Outlet Strip, Sockets Plus, Perma Power, Serial: 265-8533 (Mov Surge Protected)

---

**PART I: CHARACTERISTICS OF AN AC LINEAR VARIABLE DIFFERENTIAL TRANSFORMER (LVDT)**

---

**THEORY**

The LVDT will allow use to see the changing in voltage due to deflection. We will be able to find the change in AC voltage with the use of an oscilloscope. We will find several data point and plot them. From these points, we should be able to find a slope witch will be sensitivity of the LVDT. From this we can determine the voltage based on displacement or vise versa. After finding the sensitivity equation, we are able to calculate the experimental output voltage. As can be seen in Figure A1.2, we substitute the input, displacement in to our sensitivity equation and find the output voltage.

FIGURE A1.1 EQUATION

$$\text{Experimental} := \text{Sensitivity} \cdot \text{Displacment} - 97.695$$

We then find the percent error by finding the difference of experimental and true value divided be true value, as see in figure A1.3

FIGURE A1.2 EQUATION

$$\% \text{Error} := \frac{\text{Experimental} - \text{TrueValue}}{\text{TrueValue}} \cdot 100$$

**SCHEMATIC**

FIGURE: A1.3 MECHANICAL SETUP

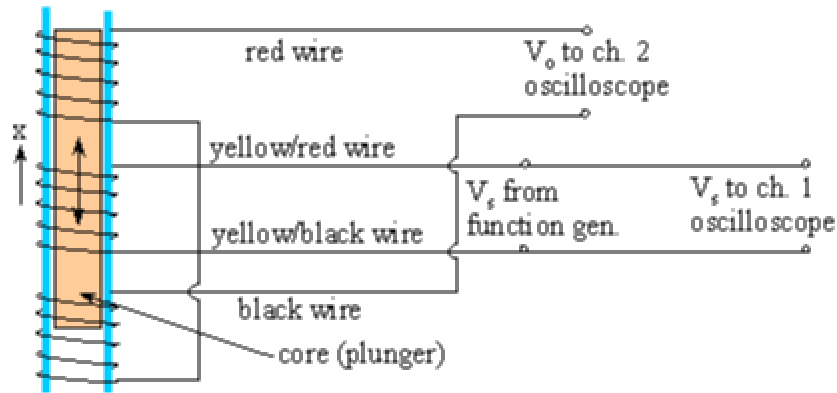

Source: spike.me.psu.edu

FIGURE: A1.4 MECHANICAL SETUP

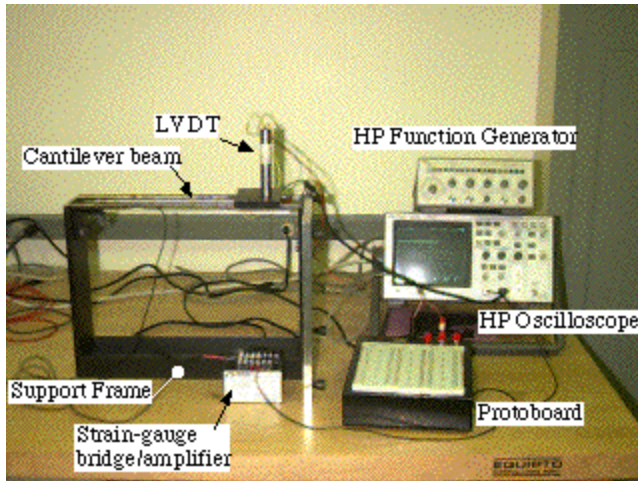

Source: mohican.me.utexas.edu

**PROCEDURE/DATA COLLECTION**

The system is set up. We set the five-kilohertz oscillator to give one and a half volts for peak-to-peak. The beam is moved from minimum to maximum and a sketch of the output form the oscilloscope is drawn. The beam is set to minimum and peak-to-peak voltage is taken. The beam is moved one millimeter and voltage is taken again. This is done for fifteen reading. We will then find the residual voltage or the minimum output voltage.

Finally, we plot our data on a graph and find the sensitivity with the slop equation. We then can find and graph our percent error over the entire distance.

### **CALCULATIONS**

$$\text{Sensitivity} := 13.295$$

$$\text{Displacment} := 15$$

$$\text{TrueValue} := 100.8$$

$$\text{Experimental} := \text{Sensitivity} \cdot \text{Displacment} - 97.695$$

$$\text{Experimental} = 101.73$$

$$\% \text{Error} := \frac{\text{Experimental} - \text{TrueValue}}{\text{TrueValue}} \cdot 100$$

$$\% \text{Error} = 0.923$$

**RESULTS SUMMARY**

FIGURE: A1.5 MAXIMUM DEFLECTION

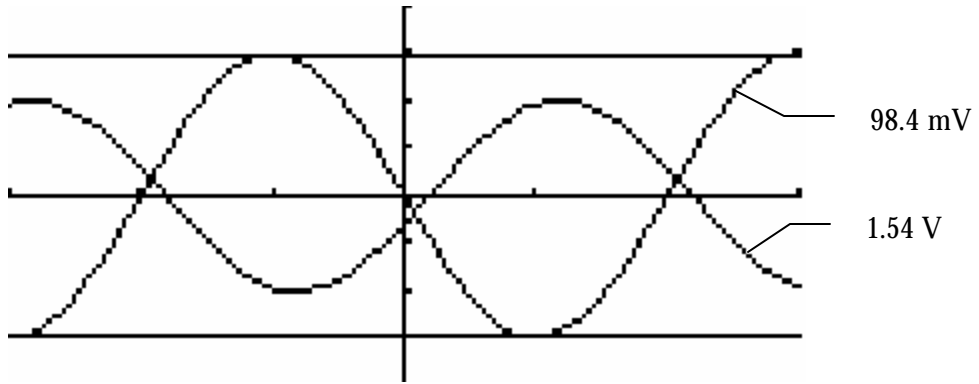

FIGURE: A1.6 MINIMUM DEFLECTION

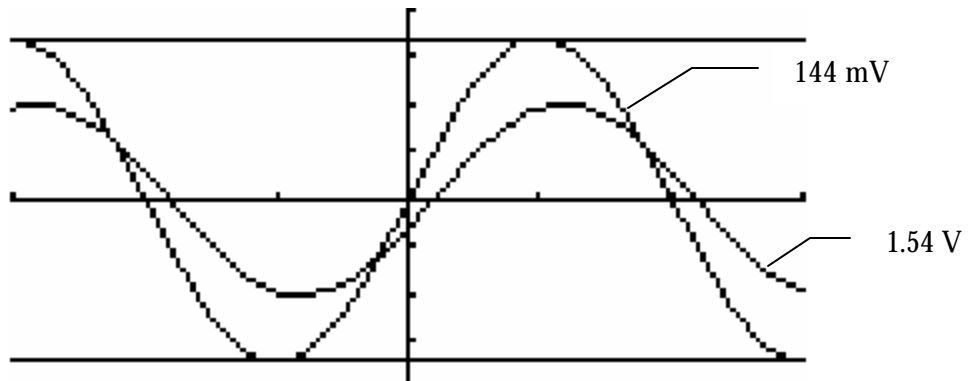

FIGURE: A1.7 NEUTRAL

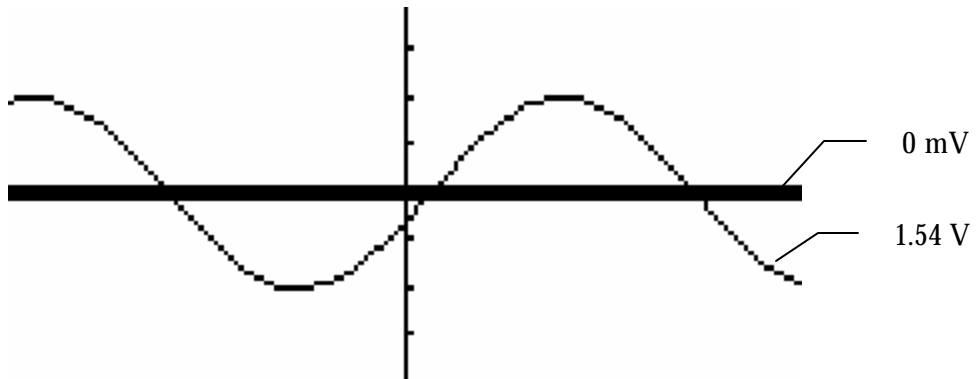

TABLE: A1.1 AC LVDT W/ % ERROR

Peak-Peak Voltage (mV)	Displacement (mm)	% Error
98.8	0.000	1%
86.0	1.000	0%
74.0	2.000	-3%
61.2	3.000	-5%
47.2	4.000	-7%
32.8	5.000	-8%
20.4	6.000	-21%
5.2	7.000	-57%
8.4	8.000	3%
21.2	9.000	4%
35.2	10.000	0%
49.2	11.000	-1%
63.2	12.000	-2%
75.2	13.000	0%
88.4	14.000	0%
100.8	15.000	1%

FIGURE: A1.8 AC LVDT

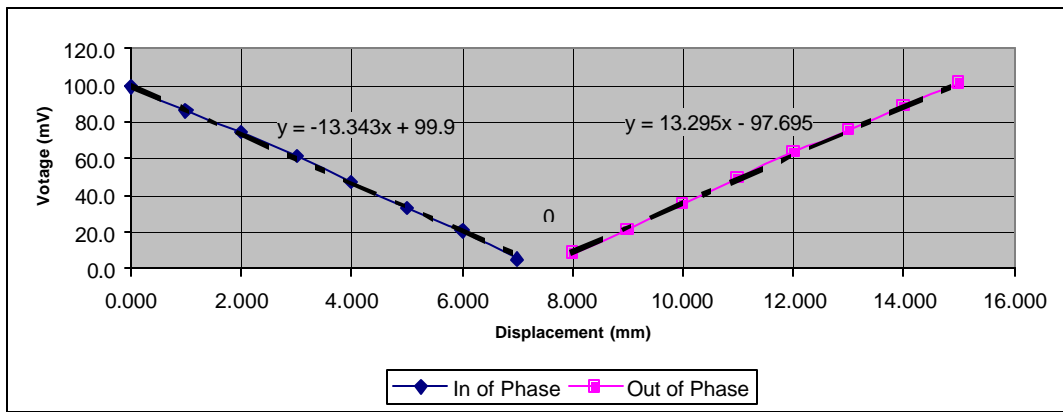
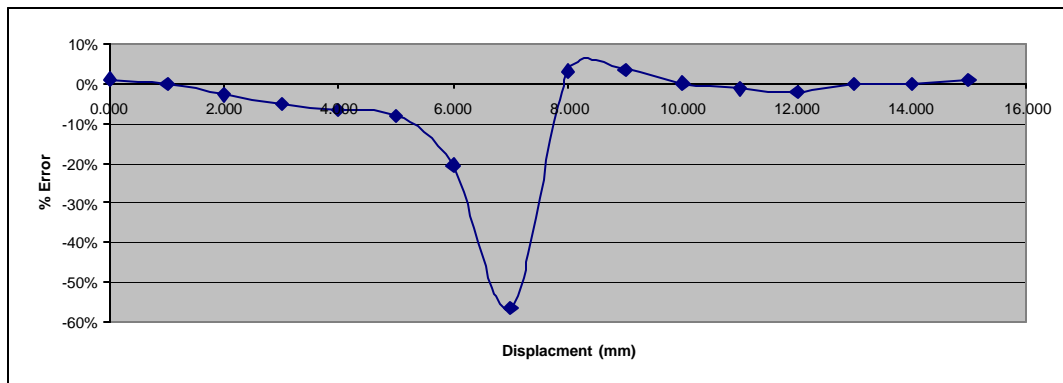

FIGURE: A1.9 % ERROR



---

## PART II: CHARACTERISTICS OF AN DC LINEAR VARIABLE DIFFERENTIAL TRANSFORMER (LVDT)

---

### THEORY

The LVDT will allow use to see the changing in voltage due to deflection. We will be able to find the change in DC voltage with the use of a multi-meter. We will find several data point and plot them. From these points, we should be able to find a slope witch will be sensitivity of the LVDT. From this we can determine the voltage based on displacement or vise versa. After finding the sensitivity equation, we are able to calculate the experimental output voltage. As can be seen in Figure A2.1, we substitute the input, displacement in to our sensitivity equation and find the output voltage.

FIGURE A2.1 EQUATION

$$\text{Experimental} := \text{Sensitivity} \cdot \text{Displacment} - 97.695$$

We then find the percent error by finding the difference of experimental and true value divided by true value, as see in figure A2.2

FIGURE A2.2 EQUATION

$$\% \text{Error} := \frac{\text{Experimental} - \text{TrueValue}}{\text{TrueValue}} \cdot 100$$

**SCHEMATIC**

FIGURE: A2.3 MECHANICAL SETUP

**PROCEDURE/DATA COLLECTION**

The system is set up. This is done for fifteen reading. We will then find the residual voltage or the minimum output voltage. Finally, we plot our data on a graph and find the sensitivity with the slop equation. We then can find and graph our percent error over the entire distance.

**CALCULATIONS**

$$\text{Sensitivity} := 10.032$$

$$\text{Displacment} := .4$$

$$\text{TrueValue} := 4.000$$

$$\text{Experimental} := \text{Sensitivity} \cdot \text{Displacment} - 0.01$$

$$\text{Experimental} = 4.003$$

$$\% \text{Error} := \frac{\text{Experimental} - \text{TrueValue}}{\text{TrueValue}} \cdot 100$$

$$\% \text{Error} = 0.07$$

**RESULTS SUMMARY**

TABLE: A2.1 DC LVDT W/ % ERROR

Peak-Peak Votage (mV)	Displacement (mm)	% Error
0.013	0.000	-23%
0.997	0.100	0%
1.992	0.200	0%
2.997	0.300	0%
3.247	0.325	0%
3.499	0.350	0%
3.750	0.375	0%
4.000	0.400	0%
4.251	0.425	0%
4.500	0.450	0%
4.753	0.475	0%
5.003	0.500	0%
5.254	0.525	0%
5.560	0.560	1%
5.750	0.575	0%
6.010	0.600	0%
7.076	0.700	-1%

FIGURE: A2.4 DC LVDT

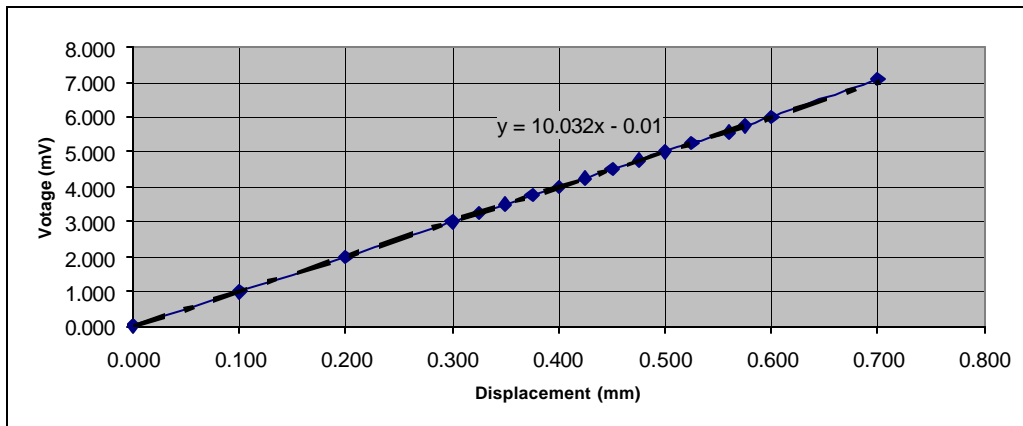
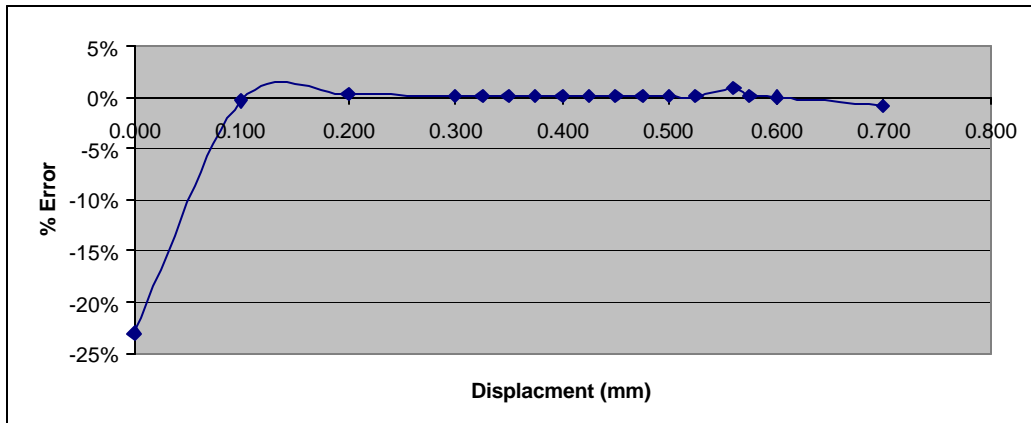

FIGURE: A2.5 % ERROR



---

### DISCUSSION

---

The AC has greater accuracy at the minimum and maximum range, where the DC has better accuracy at the mid-range. Both AC and DC LVDT's are sensitivity to a portion of a unit, within a small range. The advantage of AC is it can be that it can very accuracy determine the linear movement at just a fraction of a millimeters. The advantage of the DC is that is can be calibrated such that the data runs though the origin. The disadvantage of any LDVT is it has a short range.

---

**WORK CITED**

---

“FWL Specialists in Measurement test & Control.” [www.flw.com/lvdt\\_1.htm](http://www.flw.com/lvdt_1.htm)

“Lab 10: Measurement of Mechanical Quantities.”  
[spike.me.psu.edu/~ME082/Labs/Mechanical/lab.htm](http://spike.me.psu.edu/~ME082/Labs/Mechanical/lab.htm)

“ME 244L Note on LVDTs.”  
<http://mohican.me.utexas.edu/~lotario/me244L/labs/forcemotion/lvdt.html>